

G80-ES - GOLFARE MASCHIO

G80-ES - EYE BOLT

Lega di acciaio legato, temperato e temprato grado 80.
 Grade 80 quenched and tempered alloy steel.

Test di prova a 2,5 volte il WLL.
 Proof Load tested at 2,5 times the WLL.

Coefficiente di sicurezza 4:1.
 Safety factor 4:1.

Test di fatica a 20.000 cicli a 1,5 volte il WLL.
 Fatigue rated to 20.000 cycles at 1,5 times the WLL.

100% magnaflux per rilevare crepe.
 100% magnaflux crack detection.

Finitura superficiale: plastificata a polvere, rosso RAL3020.
 Surface finish: powder plastified, red RAL3020.



G80-ES

Golfare maschio
 Eye Bolt

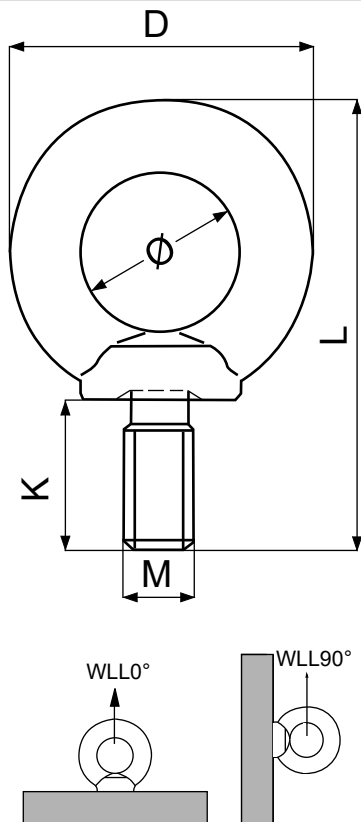

Codice Code	M	WLL 0°	WLL 90°	Peso Weight	Coppia Torque	D	K	Ø	L
	(mm)	(t)	(t)	(kg)	(Nm)	(mm)	(mm)	(mm)	(mm)
G80ES06	M6	0,4	0,15	0,05	—	28	13	16	42
G80ES08	M8	0,8	0,4	0,06	10-15	36	15	20	51
G80ES10	M10	1	0,4	0,11	10-15	45	18	25	63
G80ES12	M12	2	0,75	0,18	10-15	54	22	30	75
G80ES14	M14	3	1	0,28	20-30	63	28	35	89,5
G80ES16	M16	4	1,5	0,29	20-30	63	28	35	90
G80ES20	M20	6	2,3	0,45	50-70	72	30	40	101
G80ES22	M22	7	2,8	0,67	—	81	34,5	45	115,5
G80ES24	M24	8	3,2	0,87	130-160	90	38	50	128
G80ES27	M27	10	4	0,88	180-220	90	38	60	128
G80ES30	M30	12	4,5	1,66	200-250	108	45	60	154
G80ES33	M33	14	5	1,72	250-270	108	45	60	154
G80ES36	M36	16	7	2,65	280-400	126	55	70	183
G80ES39	M39	20	8	2,80	280-400	126	55	70	183
G80ES42	M42	24	9	4,03	500-600	144	65	80	212
G80ES45	M45	28	10	4,25	500-600	144	65	80	212
G80ES48	M48	32	12	6,38	500-650	166	70	90	238
G80ES52	M52	36	13,5	6,60	—	166,5	70	90	238
G80ES56	M56	40	15	8,80	600-900	184	80	100	267
G80ES64	M64	50	17	12,40	600-900	206	90	110	293

Il sollevamento a 90° è sconsigliato.
 Lifting at 90° is not recommended.

